

GRAPHIC SCALE



(IN FEET)
1 inch = 200 ft.

GENERAL NOTES:

- O.P.R.R.P.M.C.T. indicates Official Public Records of Real Property of Montgomery County, Texas.
- M.R. M.C.T. denotes Map Records Montgomery County, Texas.
- R.O.W. denotes right-of-way.
- U.E. denotes utility easement.
- B.L. denotes building line.
- All corners are set 5/8 inch iron rods w/cap stamped "LANDPOINT 10194172" unless otherwise shown or noted.
- Subject property is located in Zone "X", ZONE "AE", AND Floodway per Federal Emergency Management Agency's Flood Insurance Rate Map for Montgomery County, Texas, Map Number 48339C0200 G, effective date of August 18, 2014, and is partially within the 100 year floodplain.

Revised Flood Lines were approved by FEMA LOMR Case No. 17-06-0698 P with an issue date of September 29, 2017 and effective date of February 16, 2017.

- Grid coordinates shown hereon are based on Texas Central Zone FIPS 4203, (2001 ADJ.) (NAD83) and may be brought to the surface by applying the following combined scale of 0.9999914. Distances as shown are surface (ground).
- Bearings based on Texas State Plane Coordinates, Texas Central Zone FIPS 4203, (NAD83).
- No enclosed structures shall be constructed within any reserve.
- All reserves may be used for utility purposes.
- All side yard setback lines to be five feet from the side lot of an adjacent lot, unless noted otherwise (U.N.O.).
- All rear yard setback lines ten feet from an adjacent rear lot line or rear street right-of-way, U.N.O.
- D.E. denotes drainage easement.
- S.S.E. denotes sanitary sewer easement.
- ESMT. denotes easement.
- L.E. denotes landscape easement.
- One foot screen buffer along the rear lot lines for Lots 63 through Lots 75, Lots 110 through 122, Lots 124 through 135, Lot 139 and Lot 140, in Block One.
- One foot screen buffer along the south lot lines for Lots 58 and 59, in Block One.
- Rear access to Walden Road is prohibited for all residential lots.
- Home Owners Association (H.O.A.) will maintain all storm sewers within plat boundary.

JOHN CORNER SURVEY, A-8
MONTGOMERY COUNTY, TEXAS

W.W. SHEPPERD SURVEY, A-480
MONTGOMERY COUNTY, TEXAS

SURVEYOR:



Formerly
TOWN AND COUNTRY SURVEYORS
2219 SAWDUST ROAD, STE. 2003
THE WOODLANDS, TX 77380
(281)465-6730
www.landpoint.net

TBPLS REG. NO. 10194172

OWNER:

LAKE CONROE HOLDINGS, LLC
1535 N. ELSTON AVE.
CHICAGO, IL 60642

ENGINEER:

BLEYL ENGINEERING
100 NUGENT STREET
CONROE, TX 77301
PH. (936) 441-7833
FAX (936) 760-3833

DOC # 2019048230
Cabinet 002 Sheet 5824

SHEET 3 SHEET 4 SHEET 5

SHEET 6 SHEET 7 SHEET 8

RESTRICTED RESERVE	AREA	USE
(A)	0.8640 AC. 37,635 SQ.FT.	DRAINAGE
(B)	6.1117 AC. 266,225 SQ.FT.	DRAINAGE
(C)	0.2340 AC. 10,193 SQ.FT.	LANDSCAPING, UTILITIES, & DRAINAGE
(D)	0.1026 AC. 4,469 SQ.FT.	LANDSCAPING, UTILITIES, & DRAINAGE
(E)	0.2400 AC. 10,454 SQ.FT.	AMENITIES, BOAT RAMP AND DRAINAGE
	7.5523 AC. 328,976 SQ.FT.	TOTAL ACREAGE AND SQUARE FOOT OF ALL RESERVES

SAN JACINTO RIVER AUTHORITY FLOWAGE AND INUNDATION EASEMENTS:

1. Portions of the property in this subdivision are subject to one of the following:

A) A flowage and inundation easement up to the 207 M.S.L. in favor of the San Jacinto River Authority (SJRA) recorded in Volume 695, Page 40 of the Official Public Records of Real Property of Montgomery County, Texas.

B) A waiver of damages caused by flooding or inundation in favor of the San Jacinto River Authority (SJRA) 201 M.S.L. recorded in Volume 695, Page 31 of the Official Public Records of Real Property of Montgomery County, Texas.

C) A waiver of damages caused by flooding or inundation in favor of the San Jacinto River Authority (SJRA) between the 201 M.S.L. and the 207 M.S.L. recorded in Volume 695, Page 31 of the Official Public Records of Real Property of Montgomery County, Texas.

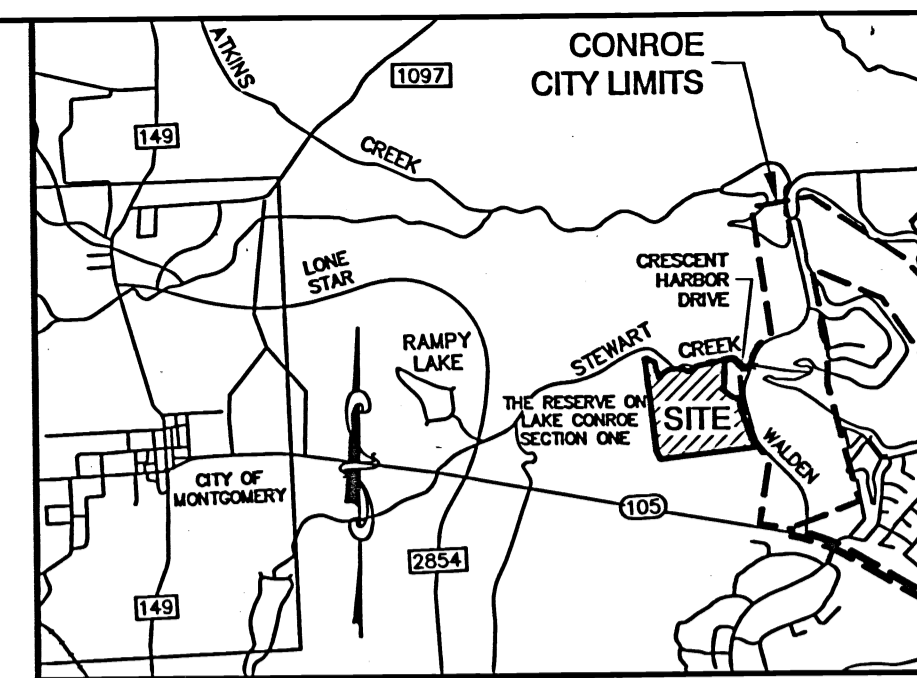

VICINITY MAP
N.T.S.

CITY OF CONROE BENCHMARK
NGS AJ6405 ELEV. 212.7 NAVD88
(2011 ADJ.)

METAL ROD, STAINLESS STEEL IN SLEEVE, LOCATED ALONG S.H. 105 +/- 30' NORTH OF CENTERLINE OF DRIVEWAY AT GATE ENTRANCE OF SAN JACINTO RIVER AUTHORITY.

NGS AJ6406 ELEV. 329.5 NAVD88
(2011 ADJ.)

METAL ROD, STAINLESS STEEL IN SLEEVE, LOCATED ABOUT 1.25 MILES SOUTH OF MONTGOMERY, 4.9 MILES EAST OF DOBBEN, 14.3 MILES WEST NORTH WEST OF CONROE. THE MARK IS ON A RAIL ROAD RIGHT OF WAY. TO REACH THE STATION FROM THE JUNCTION OF HIGHWAY 105 AND FM 149 IN MONTGOMERY, PROCEED SOUTH ON THE RIGHT. THE STATION IS A PUNCH MARK IN THE TOP OF A STAINLESS STEEL ROD DRIVEN INTO THE GROUND AND INSIDE A 1-INCH PVC PIPE THAT IS 10 FT LONG FILLED WITH GREASE THAT IS INCASED IN A 5-INCH PVC PIPE SOUTHWEST OF A SWITCHSTAND, 62.3 FEET WEST SOUTHWEST OF THE WEST RAIL ROAD CAUTION LIGHTS, 96 FT SOUTH WEST OF THE CENTERLINE OF THE RAIL ROAD CROSSING.

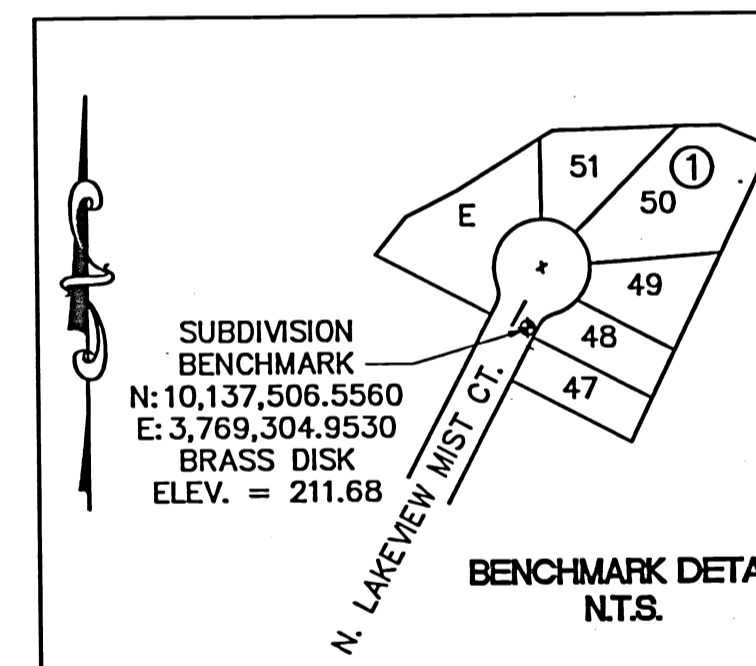

SUBDIVISION BENCHMARK
N: 10,137,506.5560
E: 3,769,304.9530
BRASS DISK
ELEV. = 211.68

BENCHMARK DETAIL
N.T.S.

THE RESERVE ON LAKE CONROE
SECTION ONE

61.87 ACRES (2,695,049 SQ. FT.)

OF LAND IN THE

JOHN CORNER SURVEY, A-8
MONTGOMERY COUNTY, TEXAS

3 BLOCKS 228 LOTS 5 RESERVES

TOTAL AREA FOR RESERVES 7.5523 ACRES

MAY 2019

SHEET 1 OF 8

STATE OF TEXAS
COUNTY OF MONTGOMERY

We, Arle Zoller and Timothy Grogan, Manager and Secretary respectively of Lake Conroe Holdings, LLC, owner of the property subdivided in the above and foregoing map of THE RESERVE ON LAKE CONROE, SECTION ONE, do hereby make subdivision of said property for and on behalf of said Lake Conroe Holding, LLC, according to the lines, streets, lots, alleys, parks, building lines, and easements thereon shown, and designate said subdivision as **THE RESERVE ON LAKE CONROE SECTION ONE**, located in the John Corner Survey, Montgomery County, Texas; and on behalf of said Lake Conroe Holdings, LLC; and dedicate to public use, as such, the streets, alleys, parks, and easements shown thereon forever; and do hereby waive any claims for damages occasioned by the establishing of grades as approved for the streets and alleys dedicated, or occasioned by the alteration of the surface of any portion of streets or alleys to conform to such grades; and do hereby bind ourselves, our successors and assigns to warrant and forever defend the title to the land so dedicated.

This is to certify that we, Arle Zoller and Timothy Grogan, Manager and Secretary respectively of Lake Conroe Holdings, LLC, owner of the property subdivided in the above and foregoing map of **THE RESERVE ON LAKE CONROE SECTION ONE**, have complied or will comply with all regulations heretofore on file with the Montgomery County Engineer and adopted by the Commissioners Court of Montgomery County, Texas.

There is also dedicated for utilities an unobstructed aerial easement five (5) feet wide from a plane twenty (20) feet above the ground upward, located adjacent to all easements shown hereon.

FURTHER, ~~owners~~ do hereby dedicate forever to the public a strip of land a minimum of fifteen (15) feet wide on each side of the center line of any and all gullies, ravines, draws, sloughs, or other natural drainage courses located in said subdivision, as easements for drainage purposes, giving Montgomery County and/or any other public agency the right to enter upon said easement at any and all times for the purpose of constructing and/or maintaining drainage work and/or structure.

FURTHER, all of the property subdivided in the above and foregoing map shall be restricted in its use, which restrictions shall run with the title to the property, and shall be enforceable, at the option of Montgomery County, by Montgomery County or any citizen thereof, by injunction, as follows:

1. That drainage of septic tanks into road, street, alley, or other public ditches, either directly or indirectly, is strictly prohibited.
2. Drainage structures under private driveways shall have a net drainage opening area of sufficient size to permit the free flow of water without backwater, and shall be a minimum of one and three quarters (1-3/4) square feet (18" diameter pipe culvert).

FURTHER, ~~owners~~ do hereby declare that all parcels of land designated as lots on this plat are originally intended for the construction of residential dwelling units thereon and shall be restricted for same under the terms and conditions of such restrictions filed separately, unless otherwise noted.

IN TESTIMONY WHEREOF, Lake Conroe Holdings, LLC has caused these presents to be signed by Arle Zoller, its Manager, thereunto authorized, attested by its Secretary, Timothy Grogan, and its common seal hereunto affixed this 21st day of June, 2018.

Lake Conroe Holdings, LLC

By: [Signature]
Arle Zoller, Manager

ATTEST: [Signature]
Timothy Grogan, Secretary

STATE OF TEXAS
COUNTY OF MONTGOMERY

BEFORE ME, the undersigned authority, on this day personally appeared Arle Zoller, Manager, and Timothy Grogan, Secretary of Lake Conroe Holdings, LLC, known to me to be the persons whose names are subscribed to the foregoing instrument and acknowledged to me that they executed the same for the purposes and considerations therein expressed, and in the capacity therein and herein set out, and as the act and deed of said ~~company~~.

GIVEN UNDER MY HAND AND SEAL OF OFFICE, this 21st day of June, 2018.

[Signature]
Notary Public for Montgomery County, Texas

Printed name Caren Lowry

My commission expires 1-31-2021

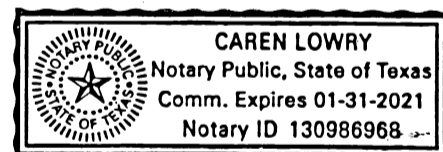

COUNTY CLERK

I, Mark Turnbull, Clerk of the County Court of Montgomery County, Texas, do hereby certify that the within instrument with its certificate of authentication was filed for registration in my office on May 23, 2018, at 4:30 o'clock P.M., and duly recorded on June 05, 2018, at 3:51 o'clock P.M., in cabinet 2, sheet 5824-31 of record of maps for said County.

WITNESS MY HAND AND SEAL OF OFFICE, at Conroe, Montgomery County, Texas the day and date last above written.

Mark Turnbull, Clerk, County Court,
Montgomery County, Texas

By: [Signature]

By: [Signature] Deputy



SURVEYOR'S CERTIFICATION

I, Jay Dean Canine, am registered under the laws of the State of Texas to practice the profession of Land Surveying and hereby certify that the above subdivision is true and correct; was prepared from an actual survey on the property made under my supervision on the ground; that the elevation benchmark reflected on the face of the plat was established as required by regulation; that all corners and angle points of the boundaries of the original tract to be subdivided of reference have been marked with iron (or other suitable permanent metal) pipe or rods having a diameter of not less than five-eighths of an inch (5/8") and a length of not less than three feet (3'); and that the plat boundary corners have been tied to the nearest survey corner.

[Signature]
Jay Dean Canine
Registered Professional Land Surveyor
Texas Registration No. 4345



I, Mark J. Mooney, P.E., County Engineer of Montgomery County, Texas, do hereby certify that the plat of this subdivision complies with all of the existing rules and regulations of this office as adopted by the Montgomery County Commissioners Court.

I further certify that the plat of this subdivision complies with requirements for internal subdivision drainage as adopted by Commissioners Court; however, no certification is hereby given as to the effect of drainage from this subdivision on the intercepting drainage artery or parent stream or on any other area of subdivision within the watershed.

[Signature]
Mark J. Mooney, P.E., County Engineer

APPROVED by the Commissioners Court of Montgomery County, Texas, this _____ day of _____, 2018.

[Signature] Commissioner, Precinct 1
[Signature] Commissioner, Precinct 2
[Signature] Commissioner, Precinct 3
[Signature] Commissioner, Precinct 4
County Judge
[Signature] MARK KEOGH

SURVEYOR:



Formerly
TOWN AND COUNTRY SURVEYORS
2219 SAWDUST ROAD, STE. 2003
THE WOODLANDS, TX 77380
(281)465-8730
www.landpoint.net
TBPLS REG. NO. 10194172

OWNER:

LAKE CONROE HOLDINGS, LLC
1535 N. ELSTON AVE.
CHICAGO, IL 60642

ENGINEER:

BLEYL ENGINEERING
100 NUGENT STREET
CONROE, TX 77301
PH. (936) 441-7833
FAX (936) 760-3833

DOC # 2019048230
Cabinet 002 Sheet 5825

THE RESERVE ON LAKE CONROE
SECTION ONE

SHEET 2 OF 8

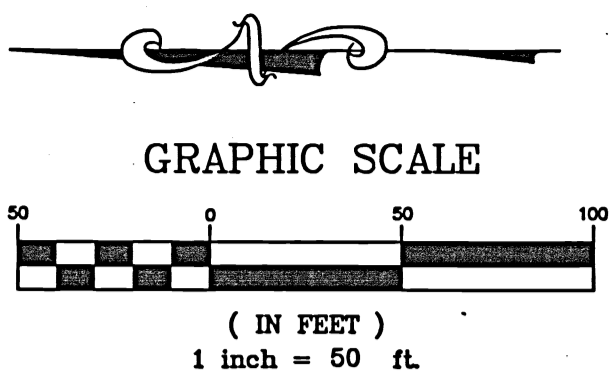

A CALLED 60.00 AND 33.6479 ACRES
TO GR PROPERTIES, L.L.C.
BY WARRANTY DEED
C.F. NO. 99099584 AND 2000-018494
O.P.R.R.P. M.C.T.

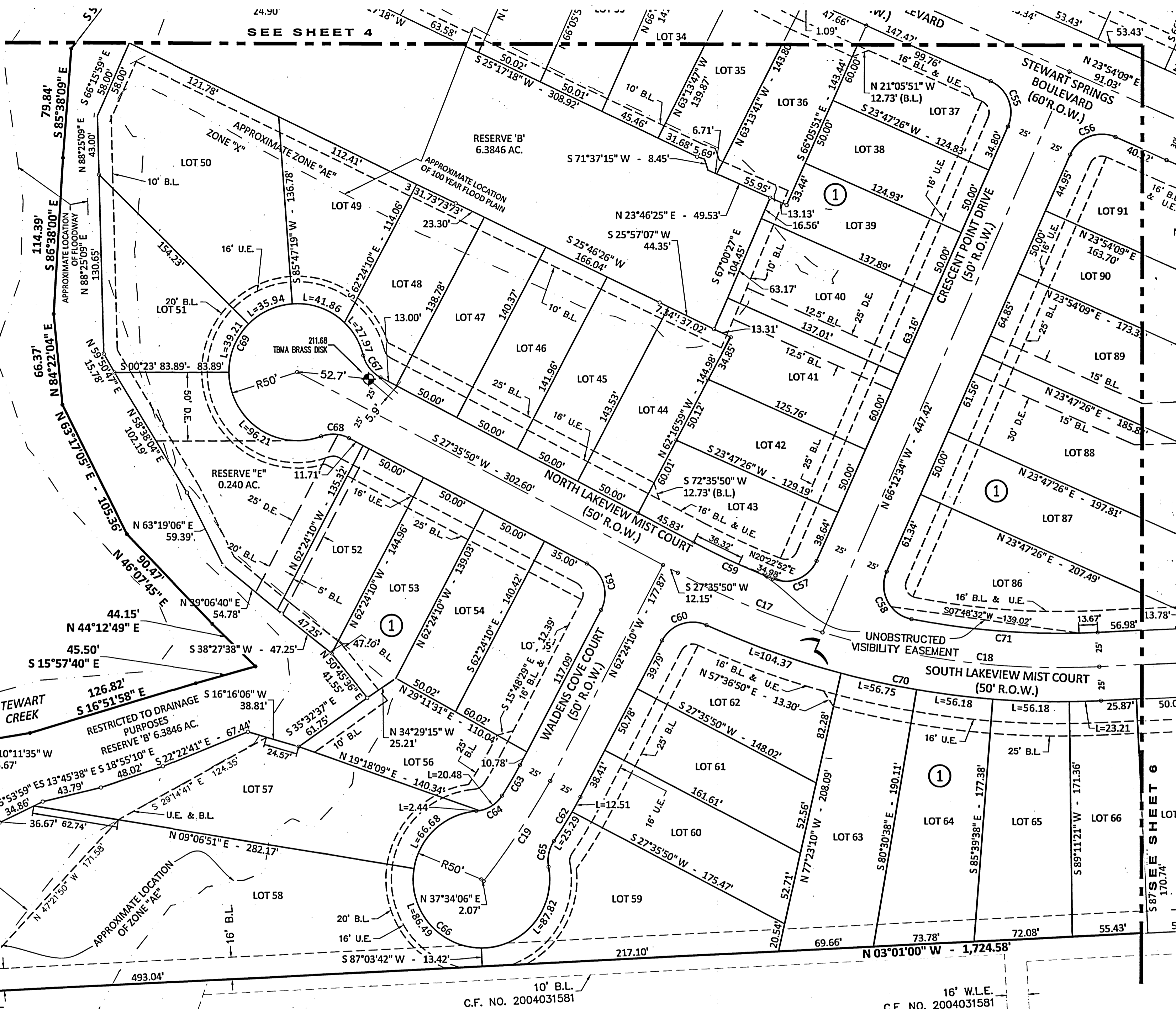

55' D.E.
C.F. NO. 2004031581
38.77'
N 63°32'32" E
5.70'
N 23°09'59" W

16' UTILITY EASEMENT
C.F. NO. 99017662

APPROXIMATE LOCATION
OF ZONE "X"

BUILDING SETBACK LINE
C.F. NO. 2004031581

MONTGOMERY I.S.D. NEW
ELEMENTARY NO. 1
CAB. V, SHEET 190
M.R.M.C.T.

10' B.L.
C.F. NO. 2004031581

16' W.L.E.
C.F. NO. 2004031581

THE RESERVE ON LAKE CONROE SECTION ONE

DOC # 2019048230
Cabinet 002 Sheet 5826

A CALLED 60.00 AND 33.6479 ACRES
TO GR PROPERTIES, L.L.C.
BY WARRANTY DEED
C.F. NO. 9909584 AND 2000-018494
O.P.R.R.P. M.C.T.

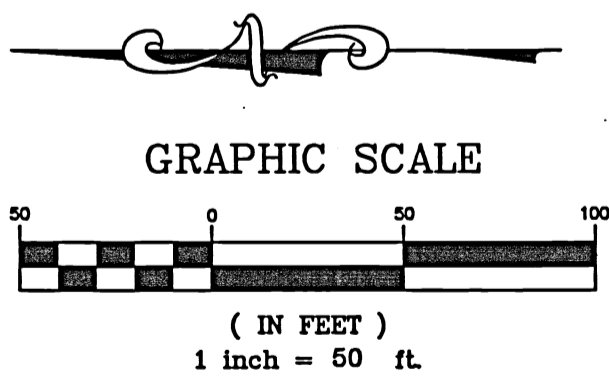

THE RESERVE ON
LAKE CONROE
SECTION ONE

DOC # 2019048230
Cabinet 002 Sheet 5827

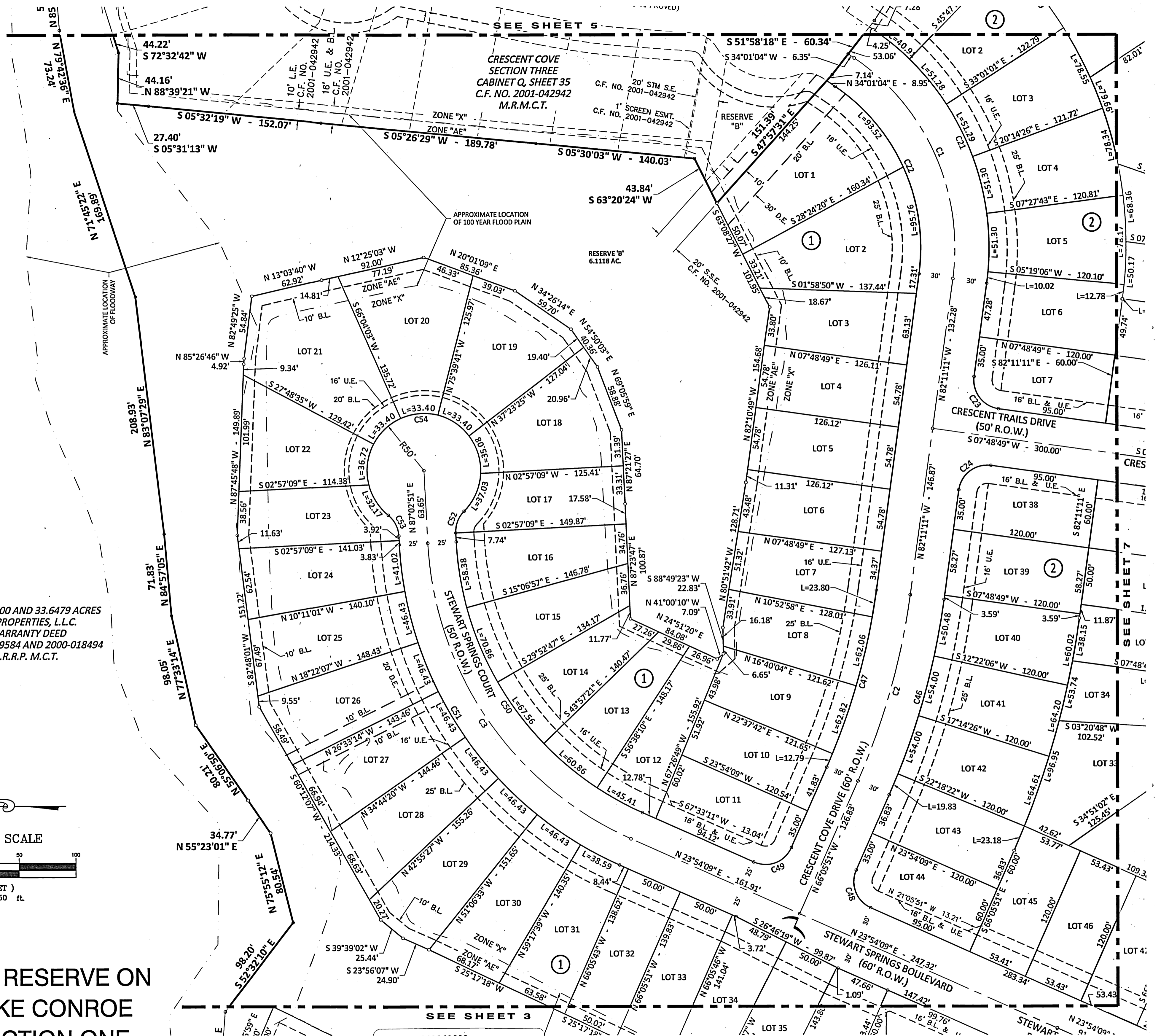

CURVE TABLE FOR STREET CENTERLINE					
NO.	LENGTH	RADIUS	DELTA	CHD. BRG.	CHORD
C1	222.69'	200.00	63°47'45"	S 65°54'56" W	211.36
C2	169.89'	605.00	16°05'20"	N 74°08'31" W	169.33
C3	330.63'	300.00	63°08'43"	N 55°28'30" E	314.15
C4	525.60'	400.00	75°17'11"	N 13°44'27" W	488.59
C5	218.92'	300.00	41°48'37"	N 72°17'21" W	214.09
C6	294.09'	300.00	56°09'59"	S 58°43'21" W	282.45
C7	36.88'	300.00	7°02'37"	S 27°07'03" W	36.86
C8	259.09'	300.00	49°28'56"	S 48°20'13" W	251.11
C9	37.73'	39.50	54°43'21"	N 54°49'31" W	36.31
C10	39.62'	39.50	57°28'20"	N 01°16'20" E	37.98
C11	67.15'	600.00	6°24'45"	N 26°48'07" E	67.12
C12	110.32'	100.00	63°12'37"	N 55°12'03" E	104.81
C13	218.92'	300.00	41°48'38"	S 72°17'21" E	214.09
C14	131.40'	100.00	75°17'11"	S 13°44'27" E	122.15
C15	34.51'	50.00	39°32'44"	S 43°40'31" W	33.83
C16	29.99'	50.00	34°21'56"	S 80°37'51" W	29.54
C17	114.45'	600.00	10°55'45"	S 22°07'58" W	114.28
C18	205.32'	600.00	19°36'23"	S 06°51'54" W	204.32
C19	87.95'	639.86	7°52'30"	N 56°22'09" W	87.88
C20	252.32'	300.00	48°11'23"	S 62°42'39" W	244.95

CURVE TABLE					
NO.	LENGTH	RADIUS	DELTA	CHD. BRG.	CHORD
C21	256.09	230.00	63°47'45"	N 65°54'56" E	243.07
C22	189.29	170.00	63°47'45"	S 65°54'56" W	179.66
C23	39.27	25.00	90°00'00"	N 52°48'49" E	35.36
C24	39.27	25.00	90°00'00"	S 37°11'11" E	35.36
C25	39.27	25.00	90°00'00"	N 37°11'11" W	35.36
C26	39.27	25.00	90°00'00"	S 52°48'49" W	35.36
C27	2.86	530.00	0°18'32"	S 82°20'27" E	2.86
C28	24.04	25.00	55°05'21"	S 70°16'08" W	23.12
C29	48.49	25.00	111°08'01"	S 26°55'42" E	41.24
C30	191.33	50.00	219°15'09"	N 27°38'58" W	94.19
C31	22.27	25.00	51°02'21"	N 56°27'27" E	21.54
C32	73.68	575.00	7°20'31"	N 27°16'00" E	73.63
C33	55.01	625.00	5°02'34"	S 26°07'01" W	54.99
C34	137.90	125.00	63°12'37"	N 55°12'03" E	131.02
C35	82.74	75.00	63°12'36"	S 55°12'03" W	78.61
C36	237.16	325.00	41°48'38"	S 72°17'21" E	231.94
C37	200.68	275.00	41°48'37"	N 72°17'21" W	196.25
C38	98.55	75.00	75°17'11"	N 13°44'27" W	91.61
C39	163.55	125.00	74°57'58"	S 13°54'03" E	152.13
C40	20.89	25.00	47°52'18"	S 00°21'14" E	20.29
C41	33.37	25.00	76°29'09"	N 62°08'43" E	30.95
C42	151.46	50.00	173°33'19"	S 62°29'17" W	99.84
C43	21.83	25.00	50°02'11"	N 55°45'10" W	21.15
C44	41.79	930.00	2°34'29"	S 80°53'57" E	41.79
C45	21.74	880.00	1°24'56"	N 81°28'43" W	21.74
C46	178.31	635.00	16°05'20"	S 74°08'31" E	177.73
C47	161.46	575.00	16°05'20"	N 74°08'31" W	160.93

CURVE TABLE					
NO.	LENGTH	RADIUS	DELTA	CHD. BRG.	CHORD
C48	39.27	25.00	90°00'00"	N 68°54'09" E	35.36
C49	39.27	25.00	90°00'00"	N 21°05'51" W	35.36
C50	303.07	275.00	63°08'43"	N 55°28'30" E	287.97
C51	358.18	325.00	63°08'43"	S 55°28'30" W	340.33
C52	21.03	25.00	48°11'23"	S 68°51'27" E	20.41
C53	21.03	25.00	48°11'23"	S 62°57'10" W	20.41
C54	241.19	50.00	276°22'46"	N 02°57'09" W	66.67
C55	39.22	25.00	89°53'17"	S 68°50'47" W	35.32
C56	39.32	25.00	90°06'43"	S 21°09'13" E	35.39
C57	38.16	25.00	87°27'30"	N 22°28'50" W	34.56
C58	44.97	25.00	103°04'17"	N 62°15'17" E	39.15
C59	63.71	575.00	6°20'55"	N 24°25'23" E	63.68
C60	37.81	25.00	86°39'43"	S 19°04'18" E	34.31
C61	39.27	25.00	90°00'00"	S 72°35'50" W	35.36
C62	37.80	325.00	6°39'49"	S 59°04'15" E	37.78
C63	25.87	275.00	5°23'23"	N 59°42'28" W	25.86
C64	22.92	25.00	52°31'54"	N 30°44'49" W	22.13
C65	19.59	25.00	44°54'00"	S 78°11'20" E	19.09
C66	240.99	50.00	276°09'28"	S 37°26'24" W	66.81
C67	21.03	25.00	48°12'28"	N 51°42'05" E	20.42
C68	21.02	25.00	48°10'17"	S 03°30'42" W	20.41
C69	241.19	50.00	276°22'46"	N 62°23'04" W	66.67
C70	296.68	625.00	27°11'51"	S 10°39'38" W	293.90
C71	137.06	575.00	13°39'26"	N 03°53'25" E	136.73
C72	25.21	25.00	57°46'09"	N 31°49'22" W	24.15
C73	239.67	50.00	274°38'20"	N 76°36'44" E	67.79
C74	16.09	25.00	36°52'12"	S 15°29'48" W	15.81

CURVE TABLE					
NO.	LENGTH	RADIUS	DELTA	CHD. BRG.	CHORD
C75	486.18	370.00	75°17'11"	N 13°44'27" W	451.95
C76	565.02	430.00	75°17'11"	S 13°44'27" E	525.24
C77	44.82	25.00	102°42'33"	S 00°01'46" E	39.05
C78	34.61	25.00	79°19'35"	N 87°17'45" E	31.91
C79	222.20	325.00	39°10'24"	N 67°13'09" E	217.90
C80	170.30	275.00	35°28'51"	S 69°03'56" W	167.59
C81	21.03	25.00	48°11'23"	N 62°42'39" E	20.41
C82	21.03	25.00	48°11'23"	N 69°05'58" W	20.41
C83	241.19	50.00	276°22'46"	S 03°11'39" E	66.67
C84	197.03	270.00	41°48'37"	N 72°17'21" W	192.68
C85	231.27	330.00	40°09'12"	S 73°07'03" E	226.56
C86	276.86	330.00	48°04'11"	N 62°46'15" E	268.81
C87	297.87	270.00	63°12'36"	S 55°12'03" W	282.99
C88	35.74	25.00	81°54'12"	N 79°41'16" E	32.77
C89	36.20	25.00	82°57'23"	N 17°52'57" W	33.12
C90	21.03	25.00	48°11'23"	N 83°27'20" W	20.41
C91	21.03	25.00	48°11'23"	S 35°15'57" E	20.41
C92	241.19	50.00	276°22'46"	N 30°38'21" E	66.67
C93	238.19	270.00	50°32'46"	N 48°52'08" E	230.54
C94	291.67	330.00	50°38'28"	S 48°54'58" W	282.27
C95	10.55	25.00	24°10'44"	S 46°02'46" W	10.47
C96	81.37	60.00	77°42'09"	S 19°17'04" W	75.28
C97	23.47	25.00	53°47'54"	S 07°07'07" W	22.62
C98	30.16	25.00	69°06'49"	N 68°34'29" E	28.36
C99	33.88	25.00	77°38'39"	S 37°06'16" E	31.35

LINE TABLE		
NO.	BEARING	LENGTH
L2	S 34°01'04" W	4.48
L3	S 47°57'31" E	7.14
L4	S 51°58'18" E	53.06
L5	N 34°01'04" E	20.48

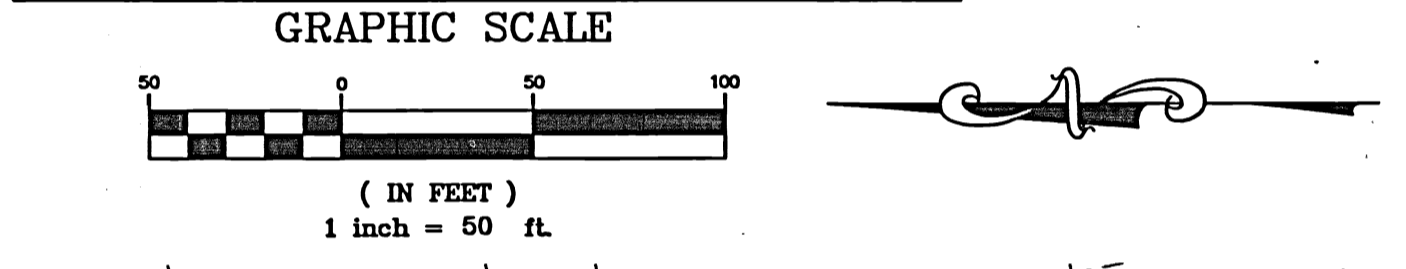

THE RESERVE ON LAKE CONROE SECTION ONE

A CALLED 60.00 AND 33.6479 ACRES TO GR PROPERTIES, L.L.C. BY WARRANTY DEED C.F. NO. 99099584 AND 2000-018494 O.P.R.R.P. M.C.T.

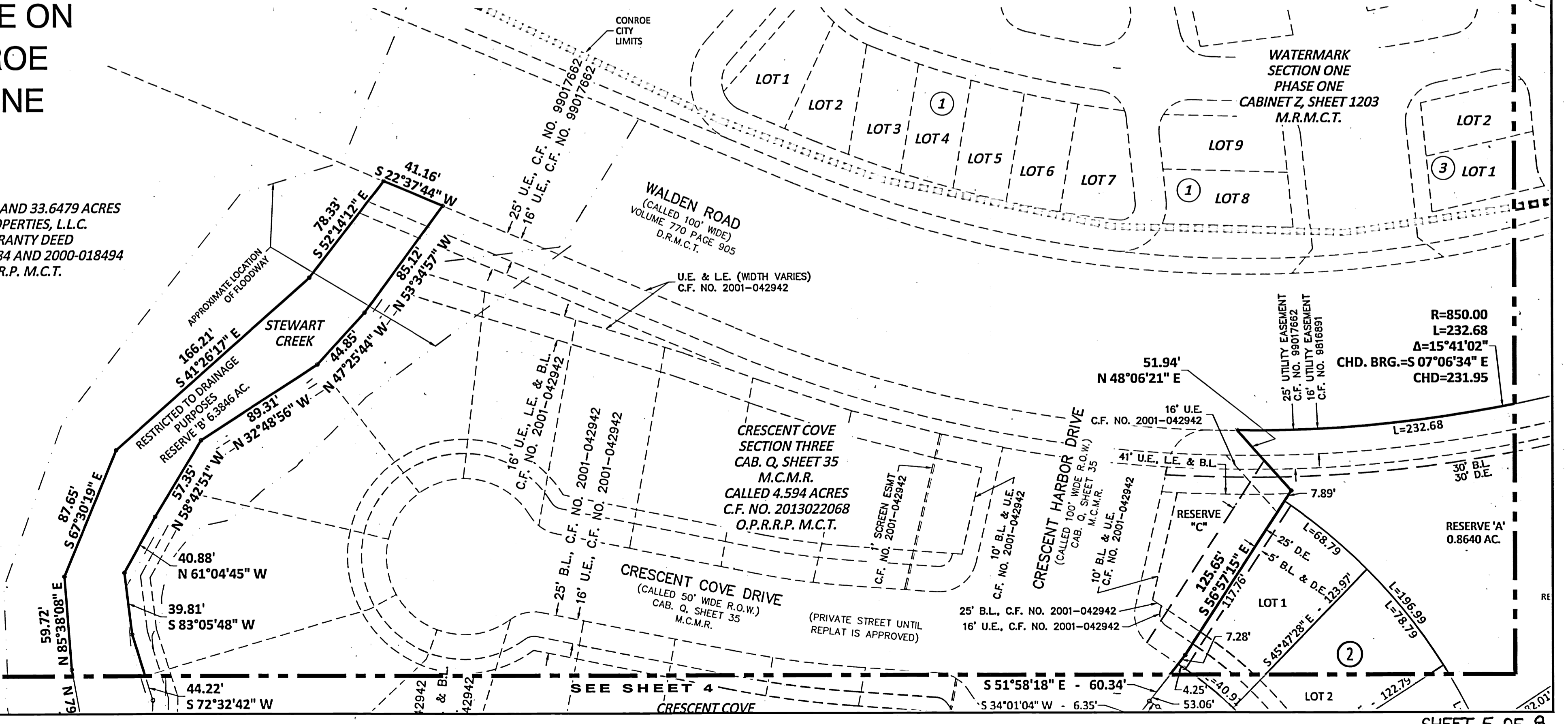

DOC # 2019048230 Cabinet 00Z Sheet 5828

SEE SHEET 4

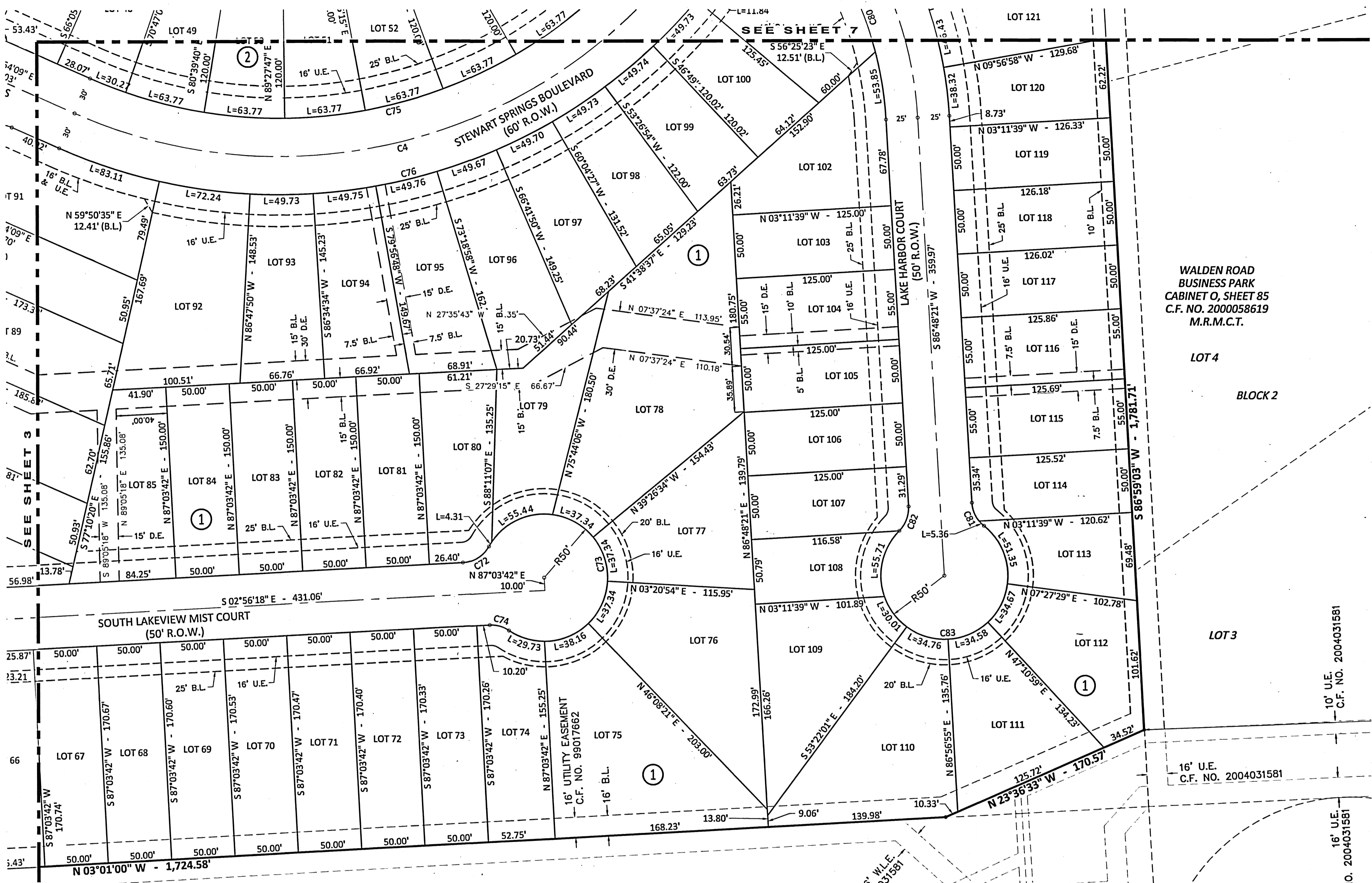

WALDEN ROAD
BUSINESS PARK
CABINET O, SHEET 85
C.F. NO. 2000058619
M.R.M.C.T.

LOT 4
BLOCK 2

LOT 3

BLOCK 1
RESTRICTED RESERVE "A"
CABINET V, SHEET 190
M.R.M.C.T.

10' U.E.
C.F. NO. 2004031581

WESTERN HILLS
COMMERCIAL
DEVELOPMENT
SECTION II
CABINET E, SHEET
69B
M.R.M.C.T.

16' W.L.E.
C.F. NO. 2004031581
CALLED 100' PRIVATE
ACCESS EASEMENT
CABINET V, SHEET 190
M.R.M.C.T.

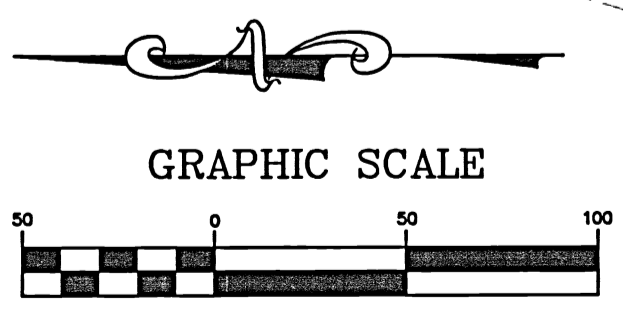

DOC # 2019048230
Cabinet 00Z Sheet 5829

THE RESERVE ON LAKE CONROE SECTION ONE

SEE SHEET 8



GRAPHIC SCALE

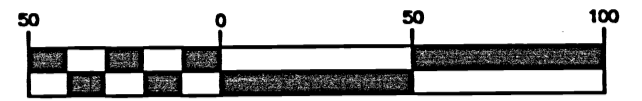

(IN FEET)
1 inch = 50 ft.

RESERVE "B"

EVANS COMMERCIAL
PARK, SECTION ONE
CABINET Z, SHEET 377
C.F. NO. 2006066895
M.R.M.C.T.

WALDEN ROAD
BUSINESS PARK
CABINET O, SHEET 85
C.F. NO. 2000058619
M.R.M.C.T.

LOT 7

LOT 6

16' U.E. & B.L.
C.F. NO. 2000058619

LOT 5

THE RESERVE ON LAKE CONROE SECTION ONE

SEE SHEET 6

DOC # 2019048230
Cabinet 002 Sheet 5830

SHEET 7 OF 8

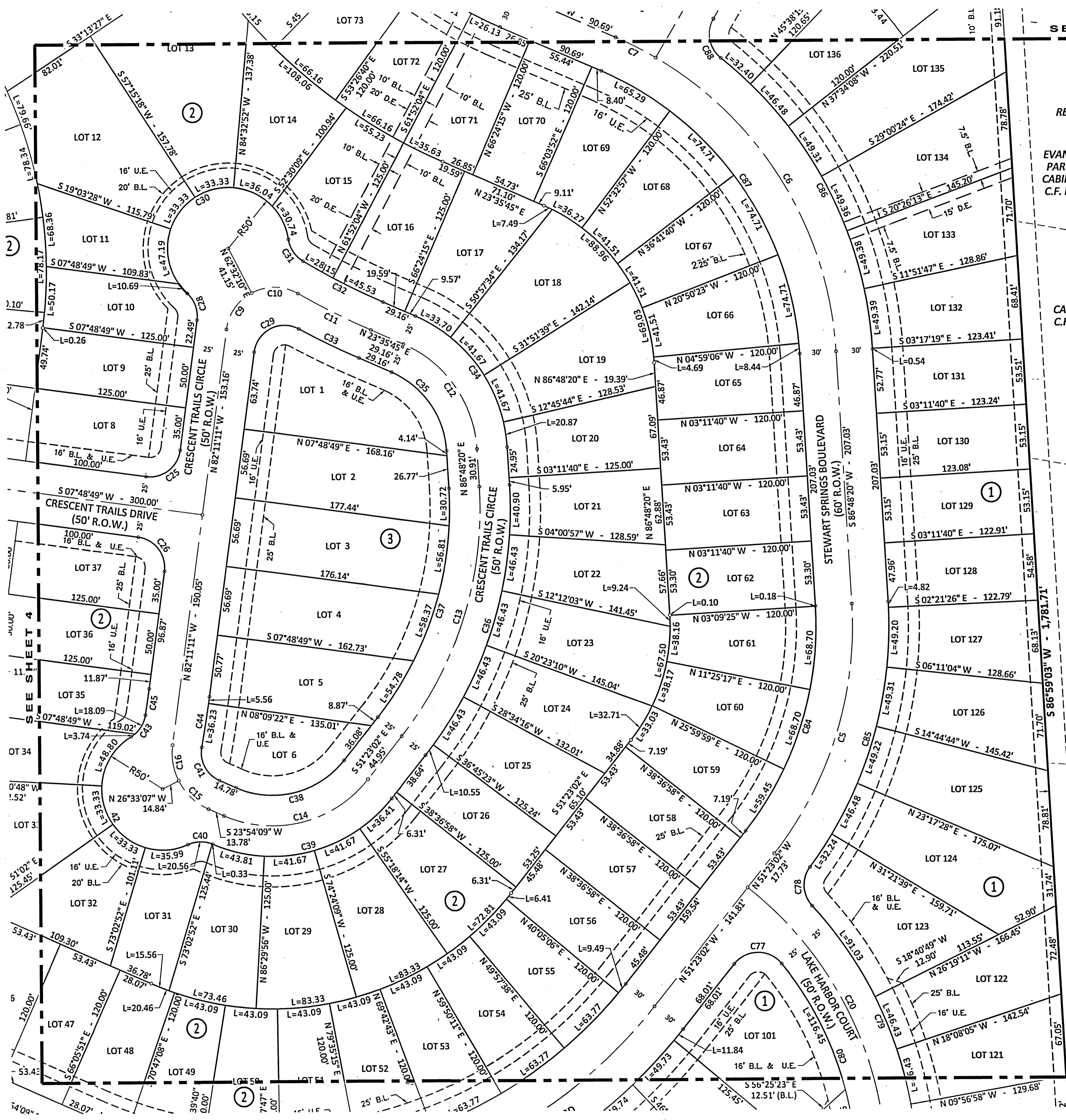

SEE SHEET 4

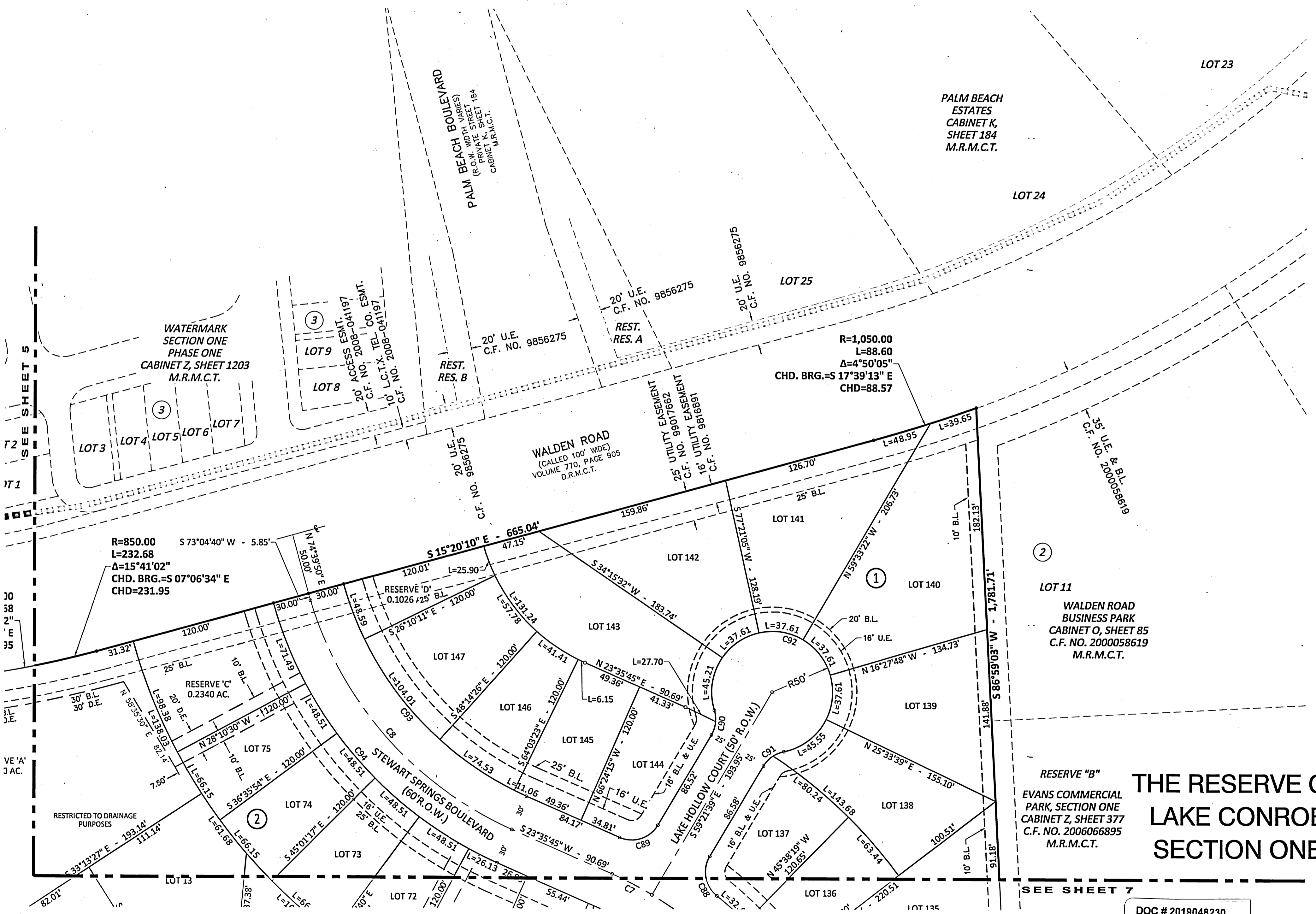
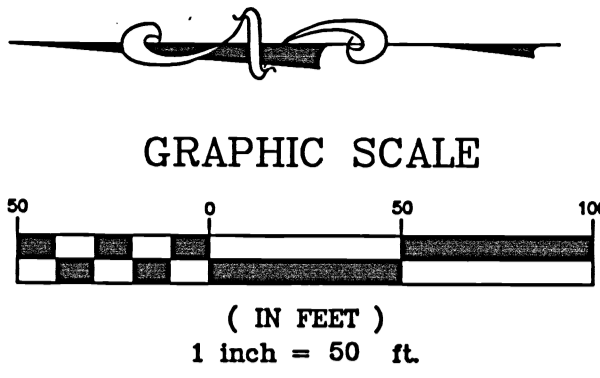

SEE SHEET 7

DOC # 2019048230
 Cabinet 002 Sheet 5831